

PLANTA

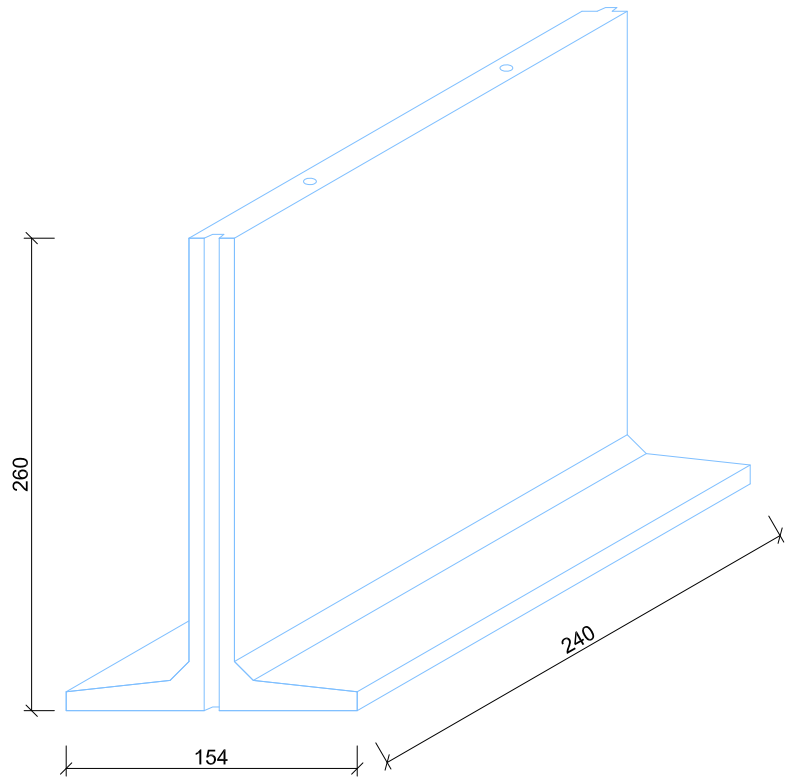

ALZADO

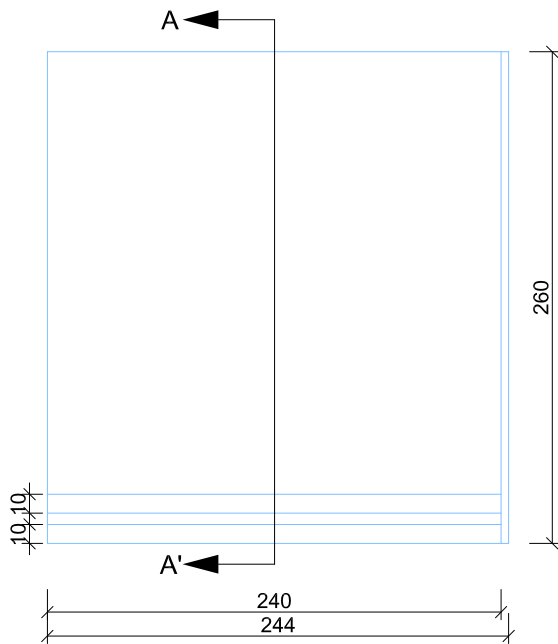

seccion A-A'

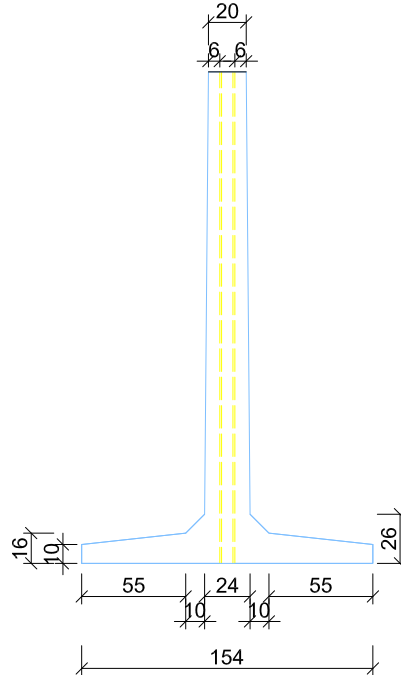

DETALLE CIMENTACIÓN

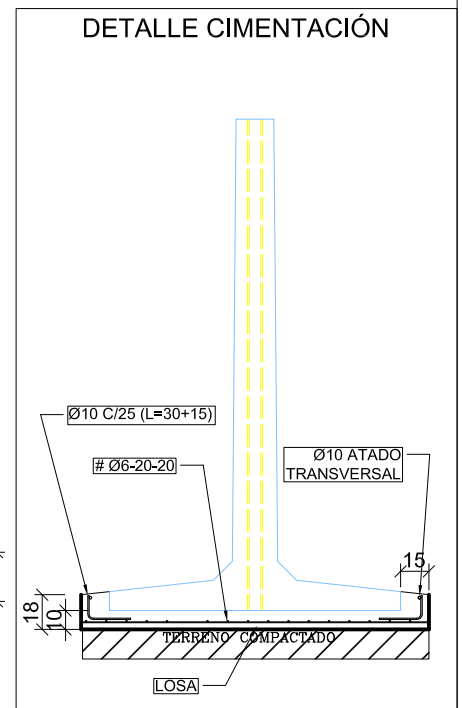

CARACTERÍSTICAS DE LOS MATERIALES

HORMIGÓN			ACERO
TIPO	CONSISTENCIA	TAMAÑO MÁXIMO DEL ARIDO	TIPO
HA-25	FLUIDA	10 mm	B-500-S



SILO 260x240

PIEZA:	SILOS 260x240	ESCALA:	1/40	PESO:	4573 kg
FECHA:	rev. 01/12	PLANO:	DETALLES SILO 260x240	REFERENCIA:	